

# DOSKO

# M296107B

MODEL NUMBER: 296107 & 296108  
SERIAL NUMBER: \_\_\_\_\_

## Owner's Manual

Instructions for Assembly and Testing

### Tow package for Stump and Root Grinders

**296107 (620-TP) tow package: 2961020 & 2961060 models**  
**296108 (337-357TP) tow package: 2961000 & 2961010 models**



#### WARNING

**READ and UNDERSTAND this manual completely before using this Tow Package.**

All operators of this equipment must read and completely understand all safety information, operating instructions.

Improper use of the tow package could result in serious injury to the operator or nearby persons.

**Any Questions, Comments, Problems, or Parts Orders**  
***Call your dealer or Dosko Customer Service 1-800-822-0295***

## Hazard Signal Word Definitions





	<p>This is the safety alert symbol. It is used to alert you to potential personal injury hazards. Obey all safety messages that follow this symbol to avoid possible injury or death.</p>
	<p>DANGER (red) indicates an imminently hazardous situation which, if not avoided, will result in death or serious injury.</p>
	<p>WARNING (orange) indicates a potentially hazardous situation which, if not avoided, could result in death or serious injury.</p>
	<p>CAUTION (yellow) indicates a potentially hazardous situation which, if not avoided, may result in minor or moderate injury.</p>
	<p>CAUTION (yellow) used without the safety alert symbol indicates a potentially hazardous situation which, if not avoided, may result in property damage.</p>

fig01453

# Table of Contents

Safety Label Location ..... 4

Machine Components Identification ..... 5

Towing Instructions..... 6

Specifications ..... 8

Parts Breakdown – Exploded View ..... 9

Safety Instructions ..... 10

Unpacking ..... 11

Assembly Instructions ..... 12

Limited Warranty ..... 15

## Safety Decal Locations

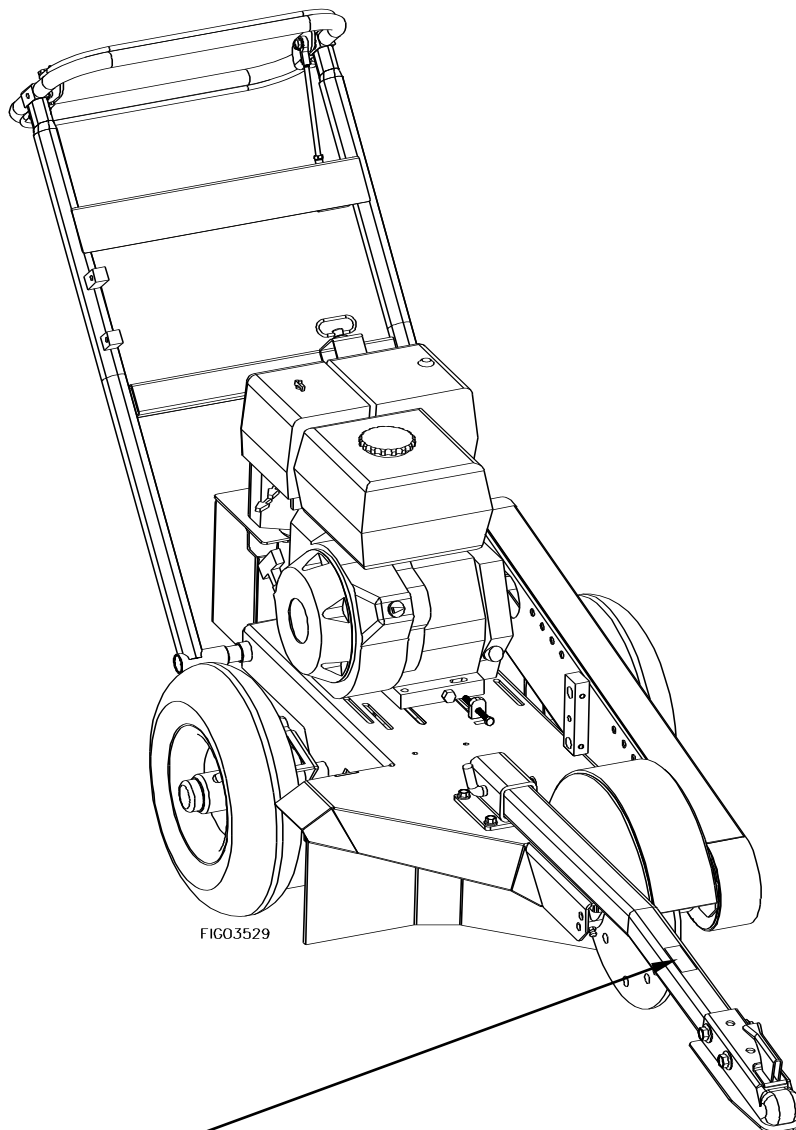

### **TOWING INSTRUCTIONS**

**NEVER TOW ON FREEWAYS  
OR MAJOR HIGHWAYS**

**NEVER EXCEED 45 MPH**  
Do Not Exceed 15 MPH When Turning  
Corners. Do Not Turn Sharp Corners

**Make Sure Safety  
Cables Are Secured  
To The Tow Vehicle**

To order replacement safety label part #785623, call Dosko Customer Service at 1-800-822-0295.

#### **⚠ WARNING**

ALWAYS make sure safety labels are in place and in good condition. If a safety label is missing or not legible, order new labels.

# Machine Components Identification

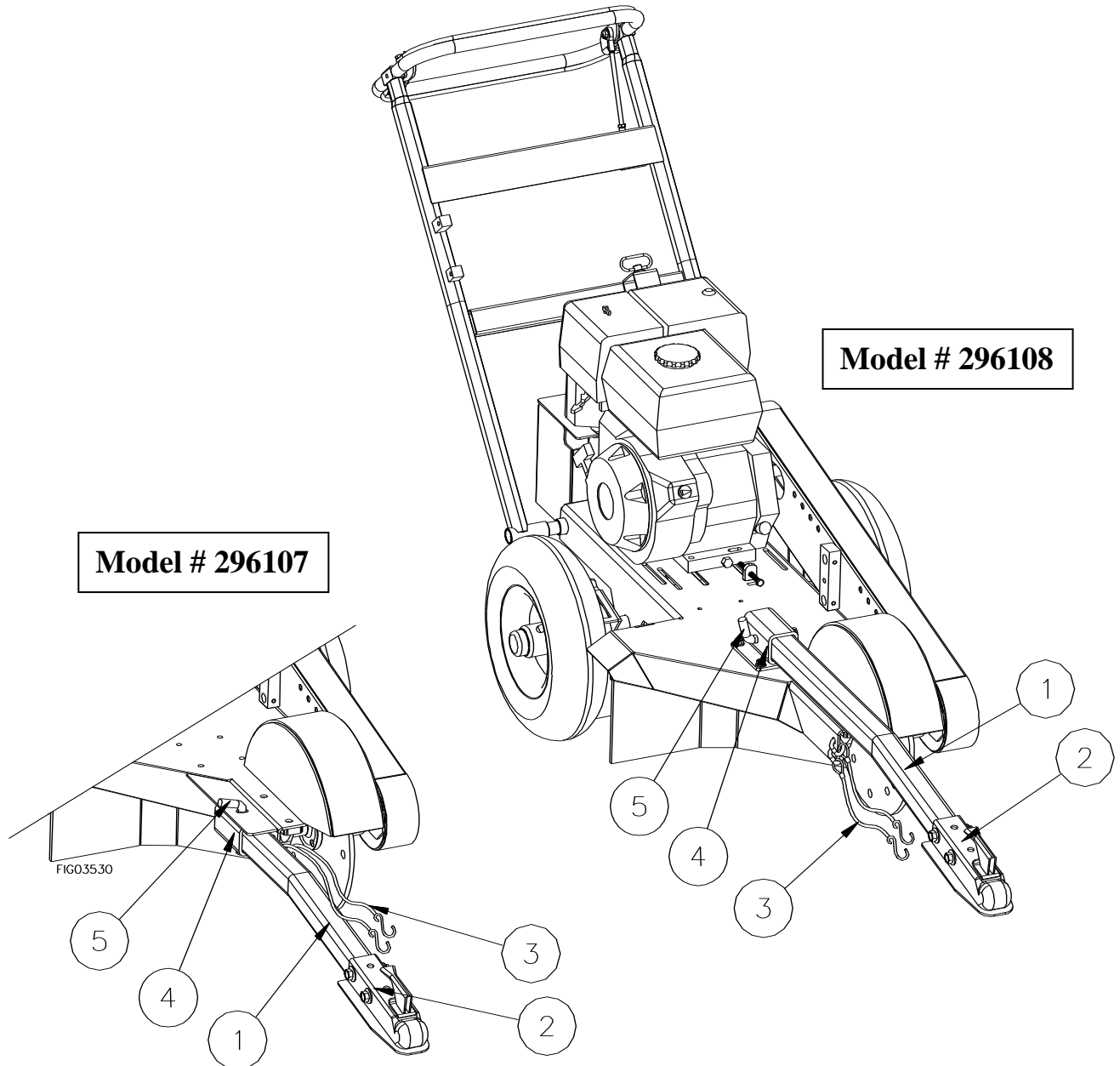

- 1.) **Tow Bar.** Connects the Stump Grinder to the tow vehicle.
- 2.) **2" Coupler.** Allows the trailer unit to be hooked up to a 2" ball hitch.
- 3.) **Safety Cables.** Secures trailer to vehicle in case of accidental disconnection of ball and coupler.
- 4.) **Tow Bar Socket.** Connects the Tow Bar to the Stump Grinder
- 5.) **Hitch Pin.** Locks tow bar into Tow Socket

All grinder units can be transported via trailers, or with the purchase of an optional towing kit package can be towed behind the vehicle.

# Towing Instructions

## IMPORTANT!

**See Assembly Instructions section of this manual to assemble the Stump Grinder Tow Package.**

Now that you have installed the Stump Grinder Tow Package, there is some important safety information you need to know with regard to vehicle handling with the Stump Grinder attached.

### **Step One. Inspect/Repair**

If the Stump Grinder has been towed previously, it must be prepared **BEFORE EACH SUBSEQUENT USE**.

### **⚠ WARNING**

Read instructions below carefully for inspecting and preparing the Stump Grinder for high speed towing. Damaged or missing components could result in injury to the operator, bystanders, or property damage.

#### **Important safety rules:**

- **Replacement parts.** If a part needs replacement, only use parts that meet the manufacturer's specifications. Replacement parts that do not meet specifications may result in a safety hazard or poor operation.

#### **Inspect and repair**

#### **Inspect and test the Stump Grinder Tow Package thoroughly**

- a. Check tires for proper pressure level.
- b. Check to be sure that all nuts and bolts are tight.

### **Step Two. Towing**

#### **1. Read instructions**

**Review towing safety instructions in your vehicle manual.**

#### **2. Check tires**

**Make sure tires are fully inflated and in good repair.**

See tire sidewall for recommended tire pressure.

#### **⚠ WARNING:**

- Do not over-inflate tires. Serious injury can occur if tire explodes.
- When seating a bead after repair, do not exceed 30 PSI. Pressures higher than 30 PSI can cause the tire and wheel to rupture and explode.

#### **3. Tow bar is secured and locked**

**Insert the tow bar into the tow bar socket. Secure the hitch pin with a cotter pin.**

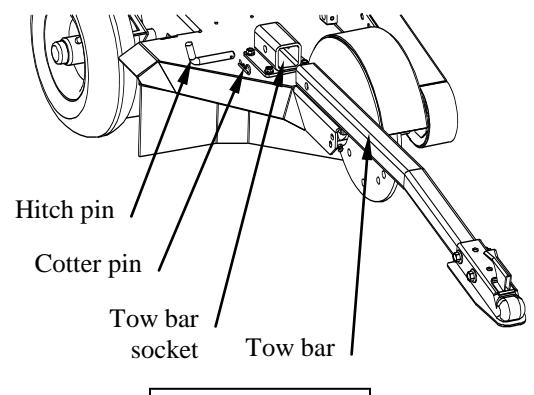
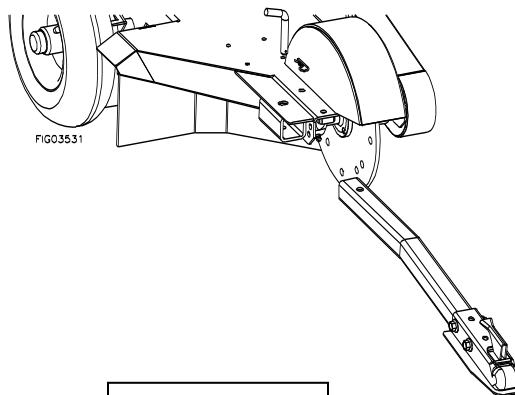

# Towing Instructions

**4. Attach to hitch  
(2" ball)**

**Attach Stump Grinder to vehicle hitch.**

Each state has legal requirements for towing equipment and trailers (such as lighting and licensing). Be sure receiver on towing vehicle is bolted tightly. Towing vehicle capability must be matched to trailer weight and type of hitch arrangement

1. Attach Stump Grinder coupler to a class 2 or higher hitch with 2" ball (only).
2. Adjust coupler to ball by raising locking lever and turning lock nut with fingers.
3. Proper adjustment is obtained when coupler is as tight as possible on ball and locking lever can still be opened and closed.
4. Close the lock lever to secure the attachment. An optional locking pin or padlock may be inserted in the locking lever hole for extra security.

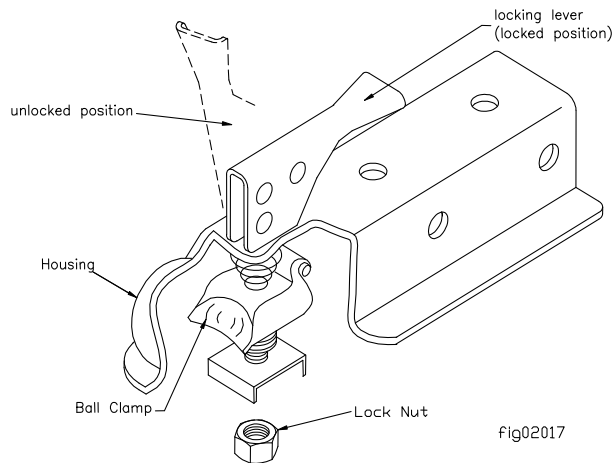

**5. Attach safety  
chains**

**Attach safety chains.**

1. Two safety chains must be used while towing.
2. Cross safety chains under the coupler allowing only enough slack for vehicle turns.

**6. Tow to desired  
location**

**Tow Stump Grinder carefully to desired work site.**

**Important safety instructions:**

- **Speed limit.** Never tow this Stump Grinder over 45 mph. Faster speeds may result in loss of control.
- **Added length.** Be aware of the added length of the Stump Grinder.
- **Rough terrain.** Drive slowly and take extra caution when traveling over rough terrain.
- **On public roads.** If towing on a public road, make sure to comply with all local, state, and federal towing requirements. It is the sole responsibility of the purchaser to obtain licensing, trailer lights, safety chains or signage, as needed to comply.
- **Unattended.** Turn off the towing vehicle before leaving the Stump Grinder unattended.
- **Under the influence.** Never tow or operate this Grinder while under the influence of alcohol, drugs, or medication

**7. Remove tow bar  
& safety chains  
after towing.**

**Remove tow bar and Safety chains after towing and before operating your Stump Grinder.**

NEVER operate Stump Grinder while the Tow Bar or Safety Chains are attached.

## Specifications

Maximum Towing Speed.....	45 MPH
Coupler Size.....	2" Ball
Overall Dimensions (boxed).....	39.5"L x 7"W x 4.5 "H
Weight (shipping).....	20 lbs.

**The manufacturer reserves the right to make improvements in design and/or changes in specifications at any time without incurring any obligation to install them on units previously sold.**

**Any Questions, Comments, Problems, or Parts Orders**  
***Call your dealer or Dosko Customer Service 1-800-822-0295***



# Parts Breakdown – Exploded View

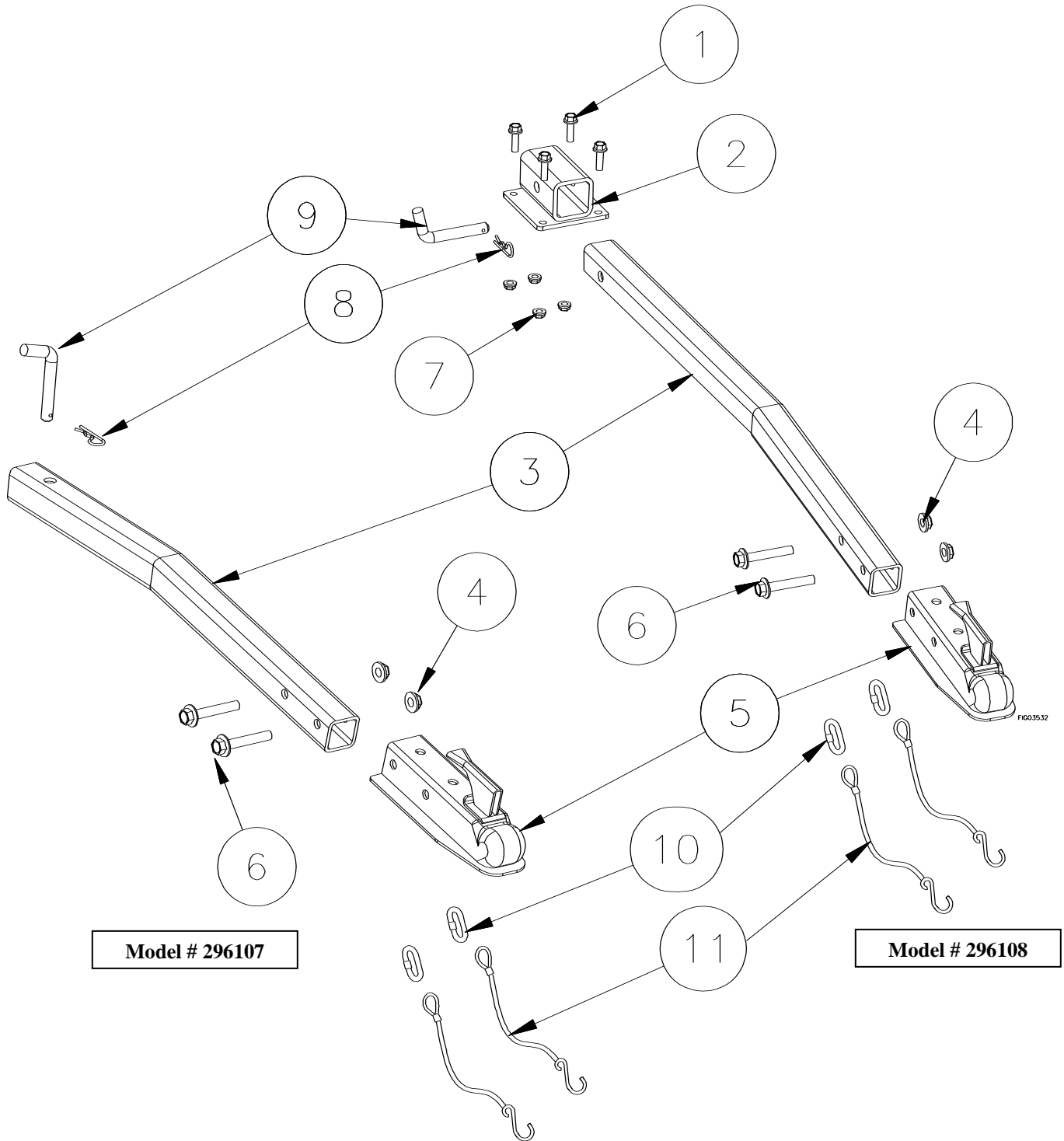

**Model # 296107**

**Model # 296108**

Item	Part #	Description	Model	Qty
1	82024	3/8" x 1-1/4" Bolt	296108	4
2	783488	Tow socket	296108	1
3	784044 783488	Tow bar	296107 296108	1
4	82291	1/2" Flange nut	All	2
5	38587	2" Ball coupler	All	1

Item	Part #	Description	Model	Qty
6	82118	1/2" x 3" Bolt	All	2
7	82290	3/8" Lock nut	296108	4
8	30312	Cotter pin	All	1
9	37459	Hitch pin	All	1
10	783948	Threaded connector	All	2
11	779542	Safety cable	All	2

# Safety Instructions

## WARNING

Carefully read and make sure you understand the following safety information before towing the Stump Grinder.

Improper use or maintenance of the Stump Grinder can result in serious injury to the operator or bystanders.

## Safety in Moving and Towing the Stump Grinder

### WARNING

The Stump Grinder is very heavy. It can crush and cause serious injury if it rolls out of control or tips over. Follow the instructions below for safely moving and towing the Stump Grinder.

### Safety – Before Use

Always inspect your Stump Grinder before each use, and repair as needed, to keep it in safe working condition:

- **Read manual.** Do not allow anyone to tow the Stump Grinder who has not read the Owner's Manual.
- **Review safety rules.** Before towing this Stump Grinder, review the instructions for safe towing. Failure to follow these instructions may result in serious injury to the operator or bystanders.
- **Mechanical parts.** Check to be sure all nuts and bolts are tight to make sure the Stump Grinder is in safe working condition.
- **Tires.** Be sure tires are fully inflated and in good repair before towing the Stump Grinder. When adding air to tires, do not over-inflate -- serious injury could occur if tire explodes.

### Safety During Towing

- **Read instructions.** Review towing safety instructions in your towing vehicle manual.
- **Securely attached.** Be sure the Stump Grinder is securely attached to the towing vehicle before towing.
- **Tires.** Be sure tires are fully inflated and in good repair before towing the Stump Grinder. When adding air to tires, do not over-inflate -- serious injury could occur if tire explodes.
- **Added length.** Be aware of the added length of the Stump Grinder.
- **Speed limit.** Never tow this Stump Grinder over 45 mph. Faster speeds may result in loss of control.
- **Rough terrain.** Be extra cautious and drive slowly when traveling over rough terrain.
- **Under the influence.** Never tow this Stump Grinder while under the influence of alcohol, drugs, or medication.
- **On public roads.** If towing on a public road, make sure to comply with all local, state, and federal towing requirements. It is the sole responsibility of the purchaser to obtain licensing, trailer lights, safety chains or signage, as needed to comply.
- **Unattended.** Turn off the towing vehicle before leaving the Stump Grinder unattended.
- **Disconnect before operate.** Do not use the Stump Grinder while it is connected to the towing vehicle.

### Safety – After use

- **Periodic maintenance.** Perform periodic maintenance as directed in this manual to keep the Stump Grinder in safe working condition.

# Unpacking

## Closely inspect all contents in the shipping carton.

- **If you have damaged components:** Contact the freight company that delivered the unit and file a claim.
- **If you have missing components:** Contact Dosko Customer Service at 1-800-822-0295.

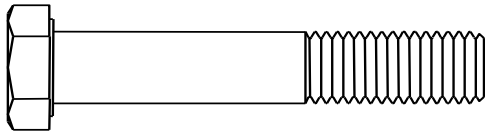

1/2 X 3" BOLT  
QTY 2

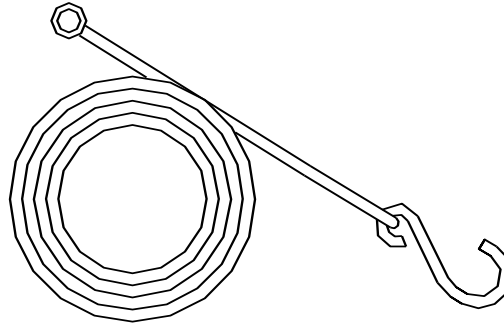

SAFETY CABLES  
QTY 2

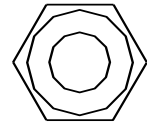

1/2" FLANGE NUT  
QTY 2

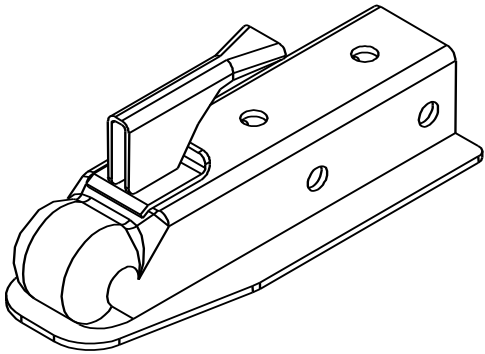

2" TOWING COUPLER  
QTY 1

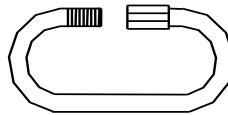

THREADED CONNECTOR  
QTY 2

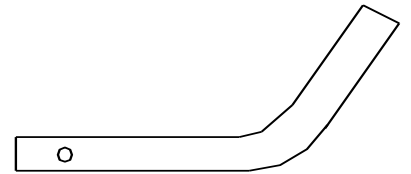

HITCH PIN w/COTTER PIN  
QTY 1

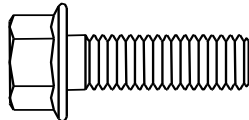

3/8" X 1-1/4" BOLT  
QTY 4  
\*296108 ONLY

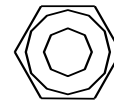

3/8" LOCK NUT  
QTY 4  
\*296108 ONLY

FIG03528

## Assembly Instructions

### Step 1 (296108 only)

- Attach Tow Bar Socket to Stump Grinder Using (4) 3/8" x 1-1/4" Bolts and (4) 3/8" Class G Locking Nuts.
- Tighten Bolts to 19 lb-ft torque.

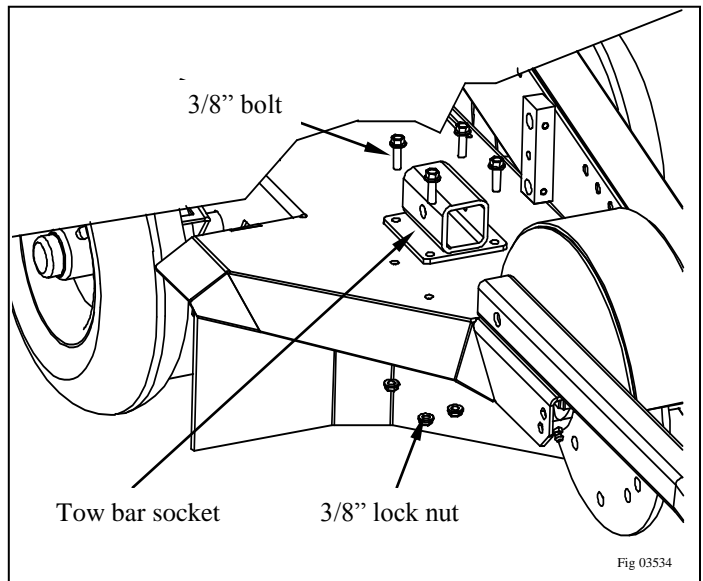

### Step 2

- Attach coupler to Tow Bar by using (2) 1/2" x 3" bolts and (2) 1/2" Class G Flange Nuts.
- Tighten Bolts to a 90 lb-ft torque.

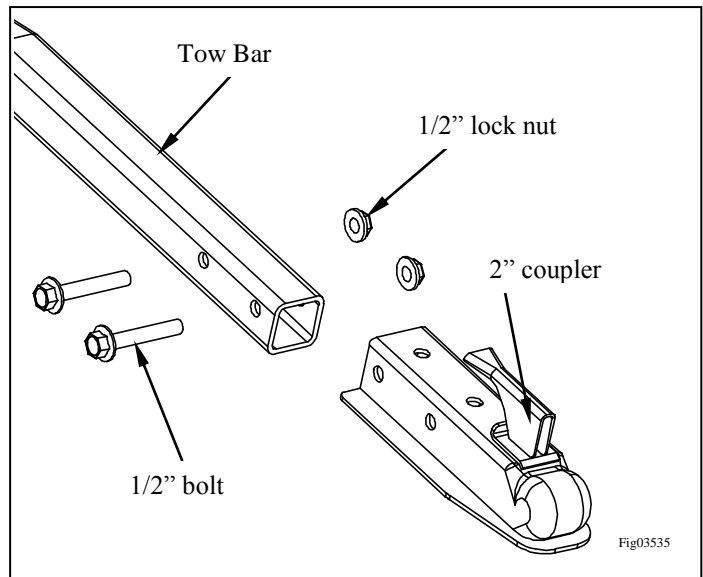

### Step 3

- Attach Safety Cables to Stump Grinder by attaching (2) Threaded Connectors to the Mounting Holes on the Stump Grinder Frame.

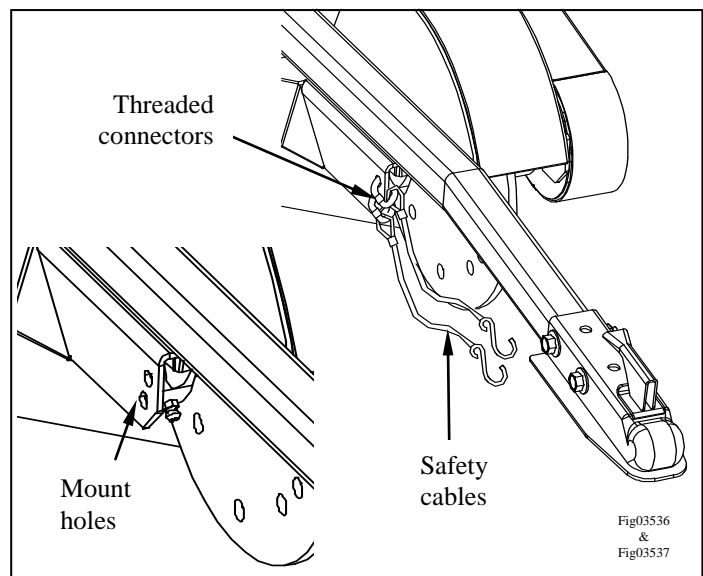

## Summary of Important Safety Information (cont'd)

### Step 4a (296107 only)

- Slide the Tow Bar into the Tow Bar Socket and secure with Hitch Pin.
- Lock Hitch Pin into position using cotter pin.

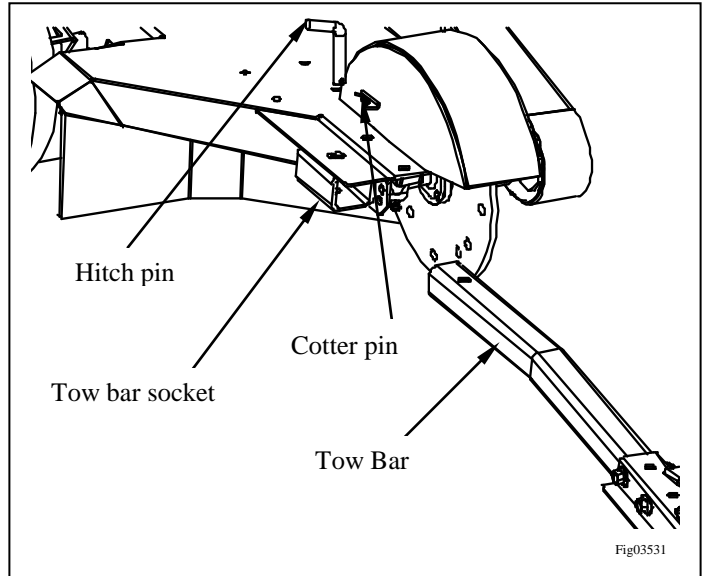

### Step 4b (296108 only)

- Slide the Tow Bar into the Tow Bar Socket and secure with Hitch Pin.
- Lock Hitch Pin into position using cotter pin.

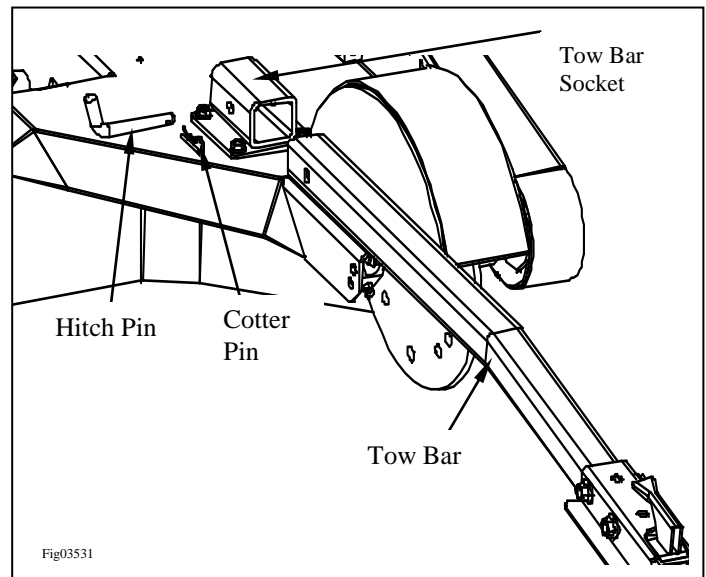

*This page has intentionally been left blank.*

# Limited Warranty Policy

August 2010

This warranty is limited to Dosko units distributed by Great Northern Equipment Distributing, Inc. 20195 South Diamond Lake Road, Rogers, MN and sold by dealers or distributors authorized to sell that product. The following warranty applies to Dosko units purchased at retail or placed into rental service on or after August 1<sup>st</sup> 2010.

Dosko warrants each Dosko unit to be free from defect in factory materials and workmanship for a period of 90 days from date of purchase or first rental. See limitations and time parameters stated below.

**DOSKO SHALL NOT BE LIABLE FOR ANY IMPLIED WARRANTIES INCLUDING THE IMPLIED WARRANTIES OR MERCHANTABILITY AND FITNESS ON ITS PRODUCTS AFTER THE 90 DAY PERIOD.**

**DOSKO WARRANTY ON ANY OF ITS PRODUCTS SHALL BE VOID IF THE PRODUCT HAS BEEN MODIFIED BY THE ADDITION OF PARTS OR THE DELETION OF PARTS. IN THIS EVENT, TO THE EXTENT PERMITTED BY FEDERAL, STATE OR LOCAL LAWS, DOSKO SHALL BE UNDER NO LIABILITY WHATSOEVER IN RESPECT TO ANY LOSS, DAMAGE, INJURY, OR EXPENSE ARISING FROM ANY DEFECTS IN ANY DOSKO PRODUCTS.**

The warranty period, as explained in the Warranty Policy, is for 90 days from the original date of sale. The fact that our product is repaired, or parts are replaced during the original 90 day period, does not extend the expiration date of the original warranty due to any loss of time resulting from failures. This warranty shall not apply to any Dosko product which has been modified, repaired, or altered in such a manner as to affect its stability, performance or operation, nor which has been subjected to misuse, abuse, negligence or accident.

The owner is responsible for all regular maintenance as explained in the operator's manual. Neglect in regular maintenance or failure to replace normal wear items such as knives, bed knife, lubrication, oils, filters, belts, bearings, etc. may void warranty.

Your authorized Dosko dealer will repair or replace, any parts that are found to be defective within the warranty period. **ALL WARRANTIES MUST BE PRE-APPROVED** through Dosko warranty department prior to any work being done. Failure to do so will void warranty and reimbursement will not be permitted. Proof of purchase date must be provided.

In order to register for the warranty on your new Dosko unit, the dealer or rental owner should fill out and return to Dosko the enclosed warranty registration cards within ten (10) days after your purchase.

---

## **“No Warranty on Purchased Wear Parts”**

Purchased wear parts (example: tires, battery, engine, belts, spark plugs, etc.) are not warranted by Dosko.

---

## **Description of Limited Warranty of Major Component Parts**

Major component failures will be handled according to Manufacturers warranty statement. Problems and defects in the engine should be referred to your authorized engine repair dealer. Other major component failures will be handled according to appropriate manufacturers warranty statement otherwise 90 day warranty applies.

---

## **Limited Warranty of Frames/Fabrication**

Dosko warrants any steel frame, tow bar, handlebar or chute for a period of two (2) years from original date of purchase to be free from defects.

# DOSKO

Great Northern Equipment Distributing Inc.  
20195 S. Diamond Lake Rd, Ste 100  
Rogers, MN 55374  
Made in USA